

VENICCI

EMPIRE

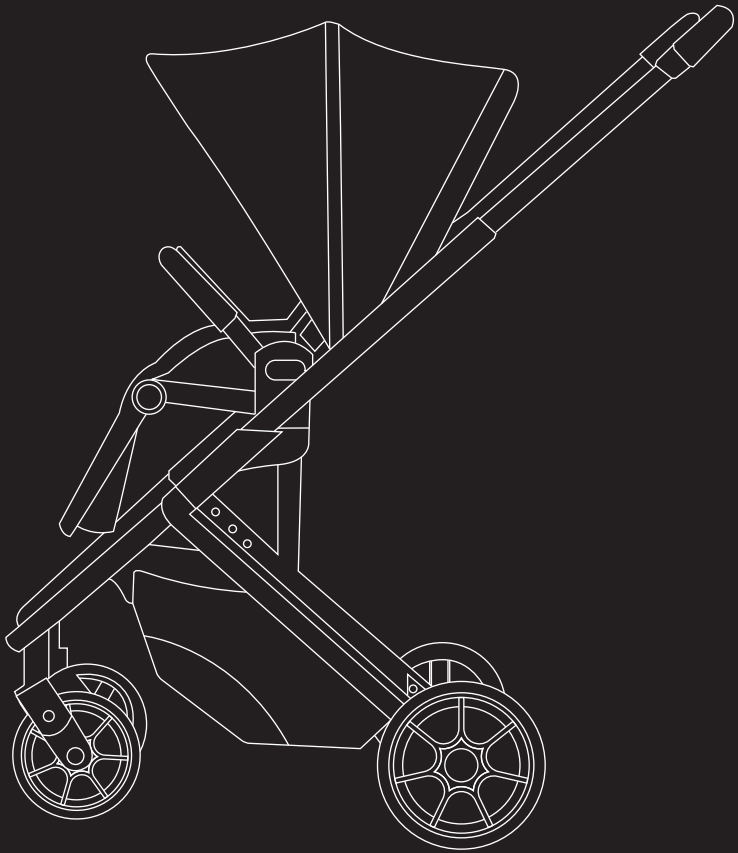

user manual & warranty

VENICCI®
— SIMPLY STYLISH —

EN

IMPORTANT - READ CAREFULLY AND KEEP FOR FUTURE REFERENCE.

WARNING!

- » Never leave the child unattended.
- » Ensure that all the locking devices are engaged before use.
- » To avoid injury ensure that the child is kept away when unfolding and folding this product.
- » Do not let the child play with this product.
- » This product is not suitable for running or skating.
- » Always engage the brake when placing the child in and taking the child out of the pram.
- » Any load attached to the handle/ back of the seat unit or both sides of the pram affects the stability of the vehicle.
- » Pram is only suitable for specified number of children and can only be used for stated age groups.
- » Before putting your child in the carry cot/pushchair seat unit/car seat make sure to check for any small objects that could cause a choking hazard.
- » Check that the pram body or seat unit or car seat attachment devices are correctly engaged before use.
- » Always use the restraint system.
- » Two-point locking system for carrycot, seat unit and car seat. The locking mechanism is triggered automatically when placed in the slots of the carrycot, seat unit, or car seat adapters
- » Buttons to deactivate the locking system. To detach carrycot, seat unit, car seat, before lifting it up, press the buttons, on the left and right side of the chassis. Before you reuse the product, ensure that the locking system is working correctly by lifting the detachable part.
- » Only use on a firm, horizontal, level and dry surface.
- » The seat unit is suitable for a maximum weight of the child 22kg or for 4 years, whichever comes first.

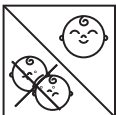

1.

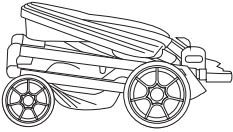

2.

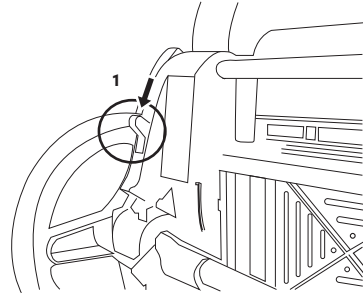

3.

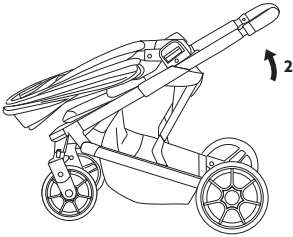

4.



5.

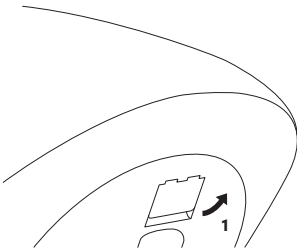

6.

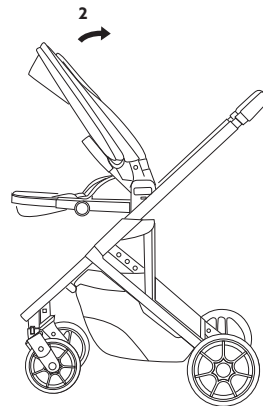

4

7.

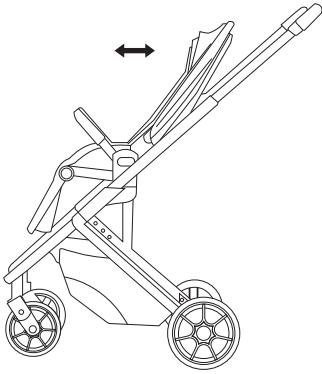

8.

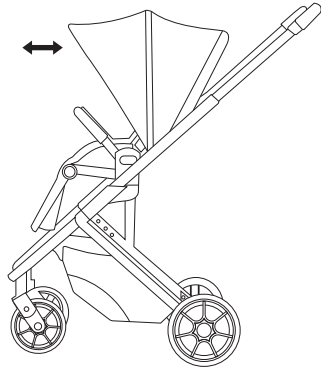

9.

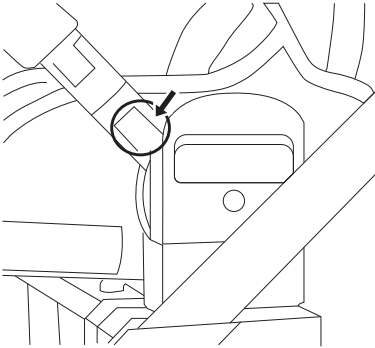

10.

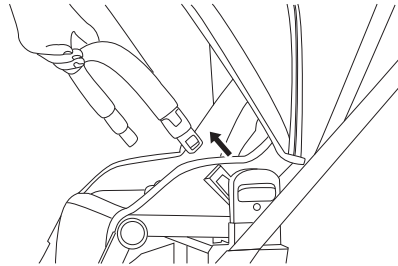

11.

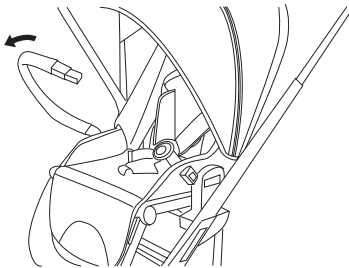

12.

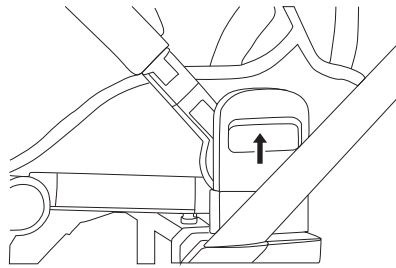

13.

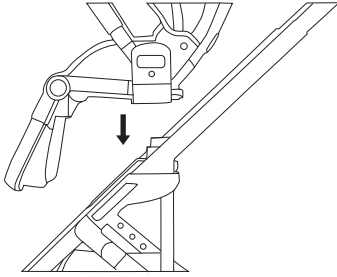

14.

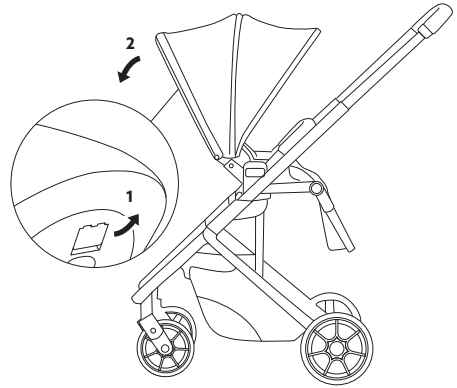

15.

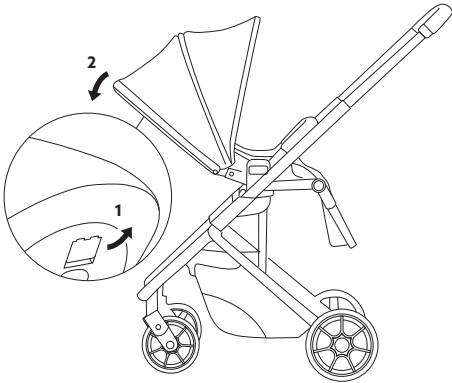

16.

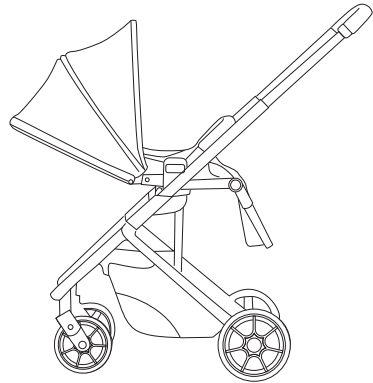

17.

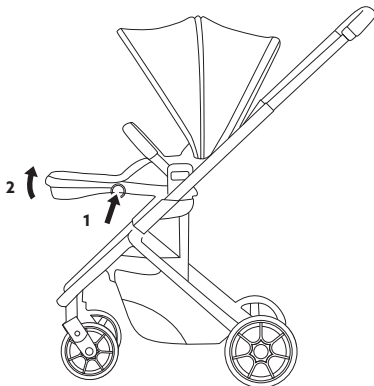

18.

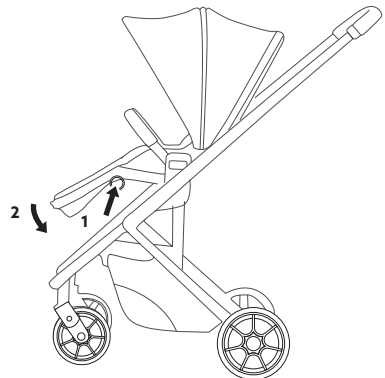

19.

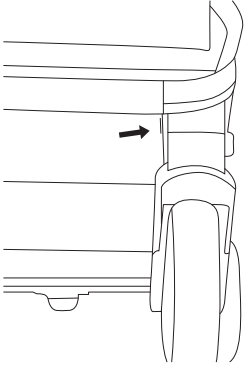

20.

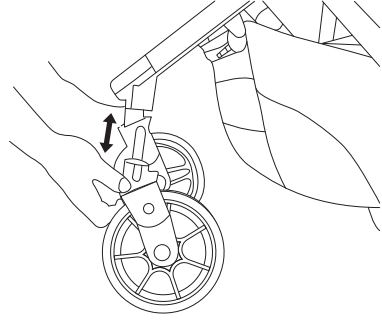

21.

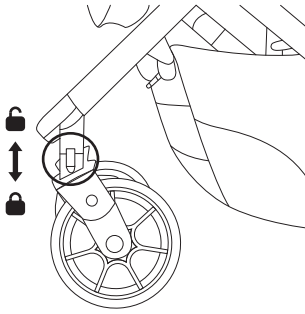

22.

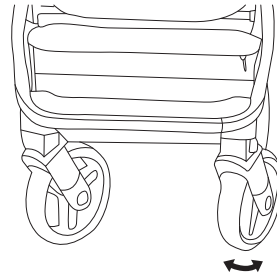

23.

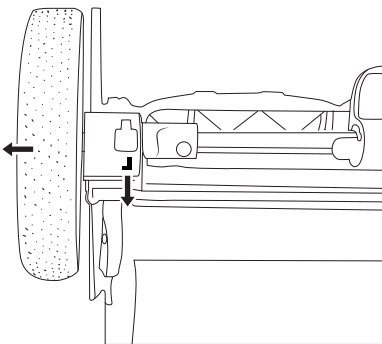

24.

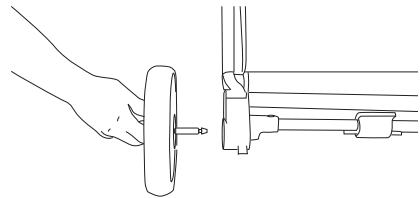

25.

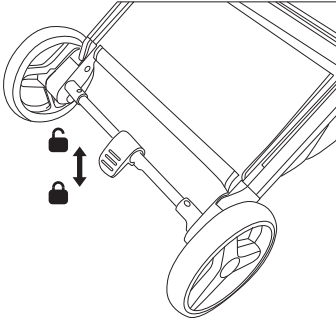

26.

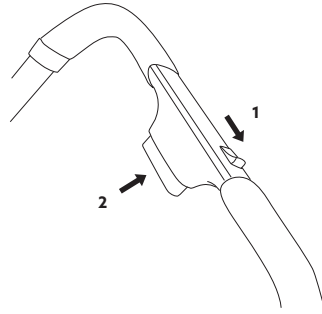

27.

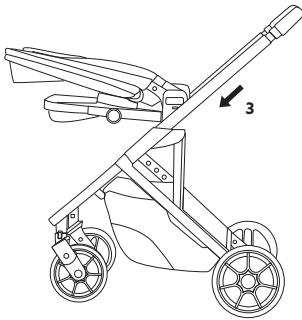

28.

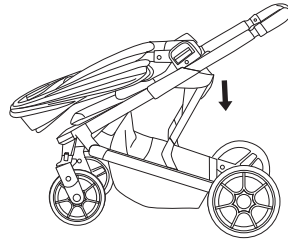

29.



30.

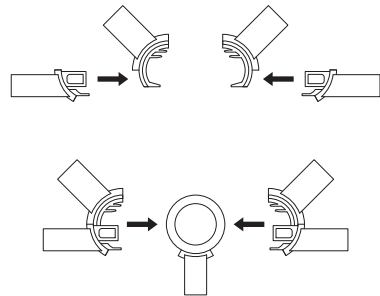

31.

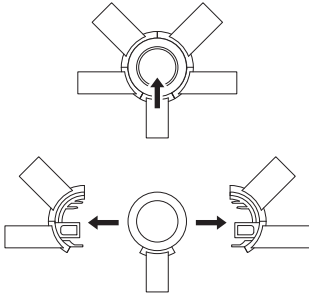

32.

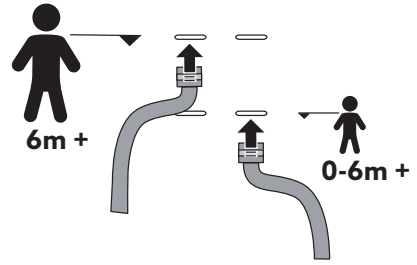

33.

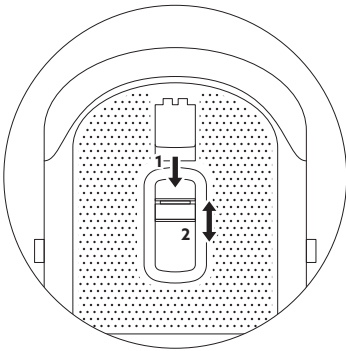

34.

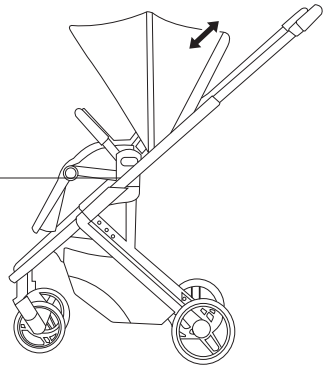

EN IMPORTANT!

- » Before use, read the following manual carefully and keep it. The safety of the child may be compromised if the recommendations included in this manual are not followed. The manufacturer of the pram is not responsible for effects from not following notes, warnings and recommendations included in the product documentation.
- » After purchased, ensure you correctly maintain all the components specified by the manufacturer in this manual guide. This pram requires regular maintenance by the user. It is the user's responsibility to undertake routine inspection and maintenance of the pram in order to avoid damage of the product and/or injury to your child.
- » Backrest adjustment in the stroller version. The stroller seat is equipped with an adjustable backrest. To lower the backrest to half-sitting or to the lying position, pull the handle in the back part of the backrest upwards, select the required position and release the handle. The backrest is equipped with a spring-loaded auto-lock mechanism that does not require the handle to be lifted when lifting the backrest from lying to sitting position. Every time you change the position of the backrest check whether the fastening system is working correctly and adjust the harness settings accordingly to fit your baby's new position.
- » Do not allow the child to stand on the seat as it may damage the stability of the stroller and cause the stroller to fall down. In order to increase the stability of the product while in use, make sure that the baby is positioned in the central part of the carrycot or the seat unit.
- » Do not carry the pram holding the hood, upper edge of the backrest, footrest or the element creating the pram version. Do not use the pram on steps or leave the pram with the child on uneven surfaces (even with the brake on) as it may go down. Carrying the pram up or down the steps, placing the pram to the bus, etc. should be carried out with the aid of another person. The person holding the pram handle tube passes the obstacle first while holding the pram handle tube, and the person holding the other end of the pram should grasp the pram by a stable element such as a fixed upright of the frame. When carrying the pram downstairs the person who is helping comes down first.
- » Pram handle height adjustment. To change the height of the pram handle, press and hold button, select the required height and release both buttons. After adjusting the height of the handle, hold it in the upper part and move it twice up and down to make sure the locks function correctly.
- » In the case of prams equipped with transferable handle tubes, ensure that the child's hands are not outside the internal outline of the seat when changing the handle tube position. After each change of the handle tube position, check the effectiveness of the self-fastening locking mechanism by pulling the handle tube up and down several times.
- » When changing the position of the backrest or the bassinet, pay attention to child's hands and head. Footrest adjustment. The pram is equipped with adjustable footrest. To lower the footrest press the adjustment buttons on both sides of the footrest, adjust the footrest position and release the buttons. The footrest is equipped with an auto-lock system that does not require the buttons to be released when lifting the footrest.

- » Do not allow the child to stand or sit on the footrest. The impact of a larger load on the footrest may cause damage to the locking mechanisms. When the child independently gets in and out of the stroller, position the footrest to its lower position.
- » Keep the pram elements clean. Dirt on the frame should be removed with a damp sponge and then wiped with a dry cotton cloth. Do not use caustic, sharp, or hard agents for cleaning as these may be harmful to the pram elements (discolouration, scratches, etc.). It is recommended to use cleaning agents appropriate for a particular surface. In the case of any dirt on the pram cover, remove it with the use of a damp sponge, adding a delicate cleaning agent. Avoid over wetting the stroller seat, bottom of the carry cot, and bottom of additional sleeping bag (pram of changeable function) as this may cause deformation of stringer ring elements.
- » To avoid weepings or smudges which may occur after rainfall, for instance, secure the pram against over soaking by the use of rain cover for the whole pram. It is recommended to protect the pram against the effects of strong sunlight. The manufacturer cannot accept responsibility for deterioration to the pram cover, which result from failure to follow these recommendations.
- » Before mounting and dismounting the wheels, lift the locking mechanism of the brake upwards (unblocked break). We recommend that the pram axles should be kept clean. Where prams are equipped with wheels without bearings, pram axles should be kept lubricated with a thick agent (cup grease, machine oil) to reduce friction on tube ends. In models equipped with wheels with bearings, it is recommended to lubricate the axles with a lubricating agent e.g. WD40. **WARNING:** Accessories or spare parts that the manufacturer or distributor has not approved must not be used.
- » For chassis equipped with mounting holes for the car seat - all connectors that the manufacturer or distributor has not approved must not be used. The manufacturer is not liable for the consequences of installing other car seats onto the chassis that do not have their approval. List of car seats with suitable approvals are posted on the manufacturer's website.
- » Adaptors for the car seat that the manufacturer or distributor has not approved must not be used. **WARNING:** Check that the car seat attachment devices are correctly engaged before use.
- » While folding and unfolding the chassis, and during assembling stage, keep your hands at a safe distance from moving parts to avoid injuries.
- » Do not use the combination of the car seat and chassis as a place for the child to sleep for long periods of time. If your child wants to sleep, always use the carry cot or cot bed. The pram is used as a means of transport, do not rock the product. Moving the pram forward and backward on short distances the front wheels should be locked on to the fixed position. Technological looseness of the spinning mechanism, may cause a change in direction which does not prove product defectiveness.
- » The manufacturer recommends fitting the car seat in the opposite direction to the direction of traveling (parent facing), it makes easier to observe the child in the car seat.
- » For pram designed from birth upwards it is recommended that the child lays in flat position at all times.
- » For carrycots equipped with a harness, always make sure that if the harness is not in

use, that it is removed from the carrycot. Carrycots fitted with top central carrying handle; before lifting ensure that the handle is positioned perpendicularly to the carrycot, and the lock in its base are turned on and working properly.

- » The load of the basket fastened to the pram frame should not exceed 3 kg, Accessible load of the bag hung on the pram handle is 1 kg. Pockets of the pram are for decorative purposes only, no objects of total weight exceeding 0.15 kg should be placed within each pocket or weight of 0.35 kg for all pockets.
- » For any warranty and post-warranty repairs only use the parts supplied or recommended by the relevant manufacturer or distributor. The pram should not be used if any sort of defect has been noticed or any of the elements have been damaged.
- » The hood of the seat unit has been designed using flexible strips of steel, which under the influence of pressure can be deformed. This may result in decreased spacing between the internal metal bars and other parts of the system and lead to damage such as causing fabric to tear. In the case of deformation you must make a correction by gently squeezing, stretching the internal metal bars.
- » In the case of travel systems fitted with reversible seat unit, it is not allowed to change its position while baby is in it.
- » After unfolding the chassis, check whether the front and rear wheels are fitted properly by trying to detach them from the chassis without pressing the button that unlocks the locking mechanism.
- » 'D' rings are provided for the attachment of an additional harness. These are located on the existing harness close to where it is attached to the seat frame. 'D' rings are provided for fitting a separate harness if required. Replacement Harness can be purchased directly from distributor.
- » Operating the parking brake. Press down on the pedal to engage the parking brake. Press down and release to disengage the parking brake. **WARNING:** Never leave the vehicle without first fully engaging the parking brake.
- » Not place the carry cot near an open fire or other source of strong heat. The handles and the bottom of the carry cot should be inspected regularly for signs of damage and wear. If the carry cot is intended to be used with a stand, then it shall be checked that the stand is the appropriate size to accommodate the base of the carry cot. The head of the child in the carry cot should never be lower than the body of the child.
- » Before carrying or lifting, make sure that the handle(s) is (are) in the correct position of use. Before carrying or lifting the base shall be adjusted in the lowest position.



EN Pram/pushchair is designed for children from birth to 4 years old.

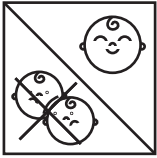

EN This product is suitable for one (1) child.



EN Stroller seat equipped with the hood and the footmuff.



EN Pram chassis with wheels.



EN The seat unit is suitable for a maximum weight of the child 22kg or for 4 years, whichever comes first.



EN Pram bag.



EN Universal rain cover for the seat unit and carrycot.



EN 1888-2:2018

Distributed in Europe: Babysky Sp z o.o Sp. k

Distributed in the United Kingdom: MAGICBABY LTD Unit 7 Brookfields Way,
S63 5DL Manvers Rotherham

Made in China

VENICCI

Made in China

For details regarding our distributor's visit:

venicci.co.uk